

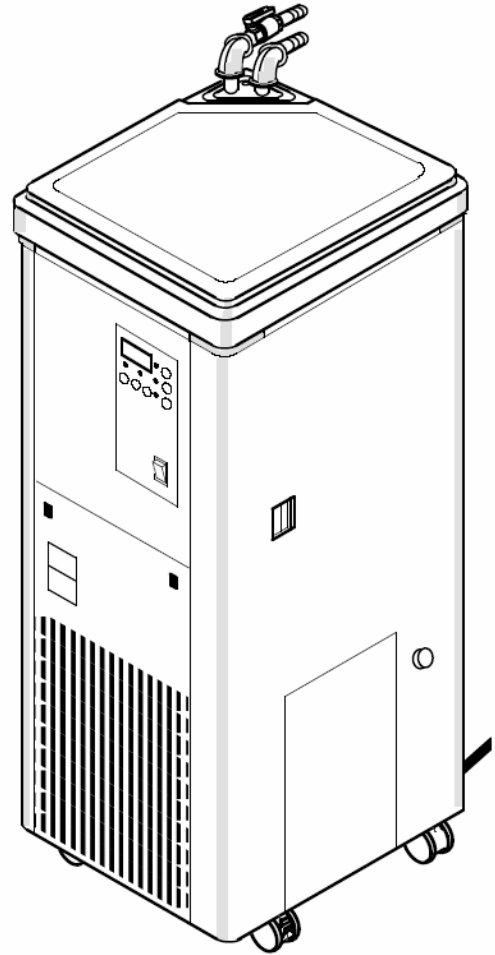

Recirculating Coolers

SRC3 SRC14

Instructions for use

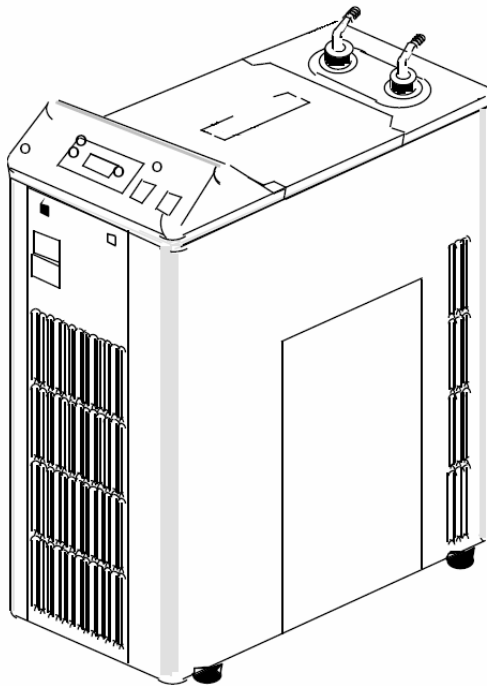

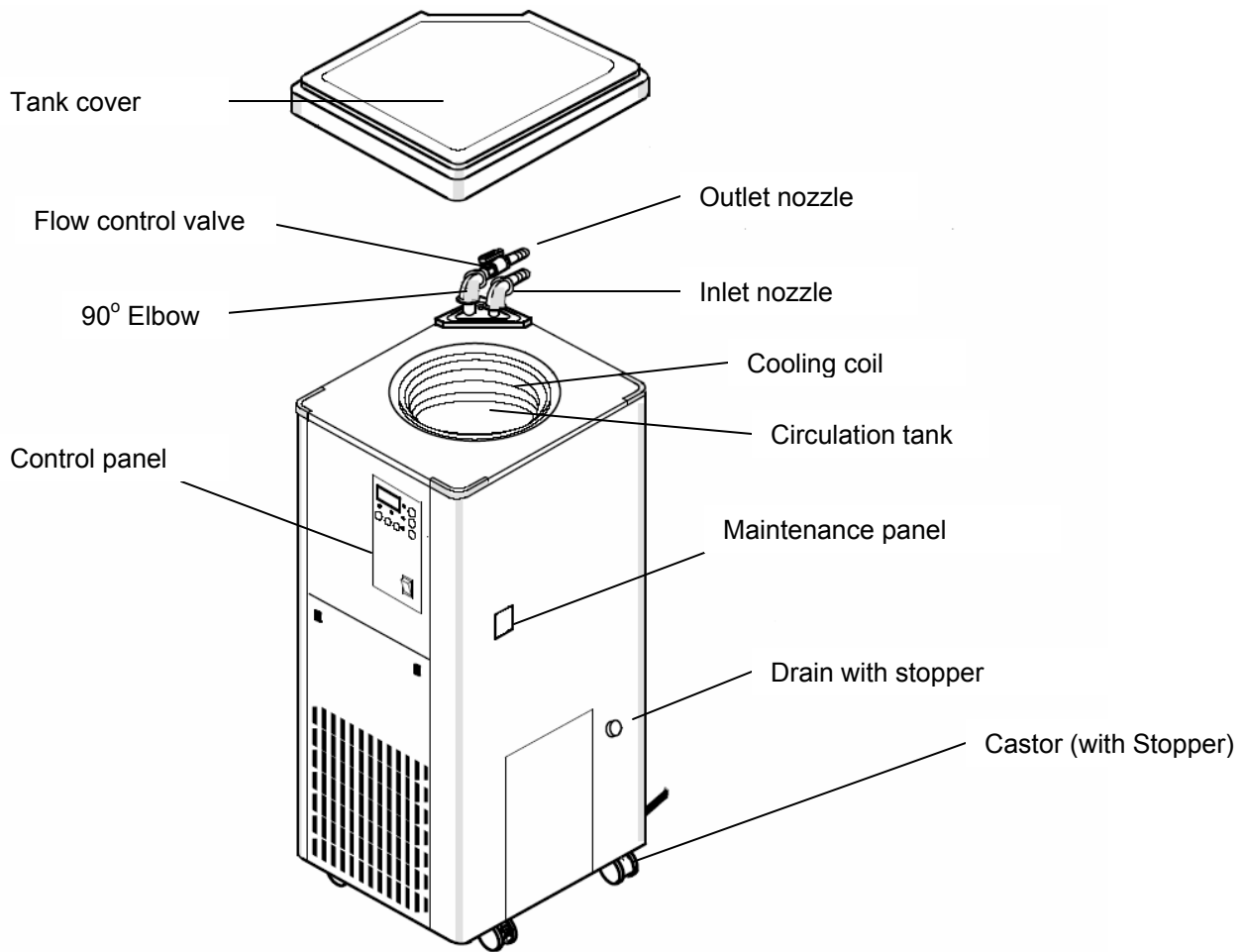
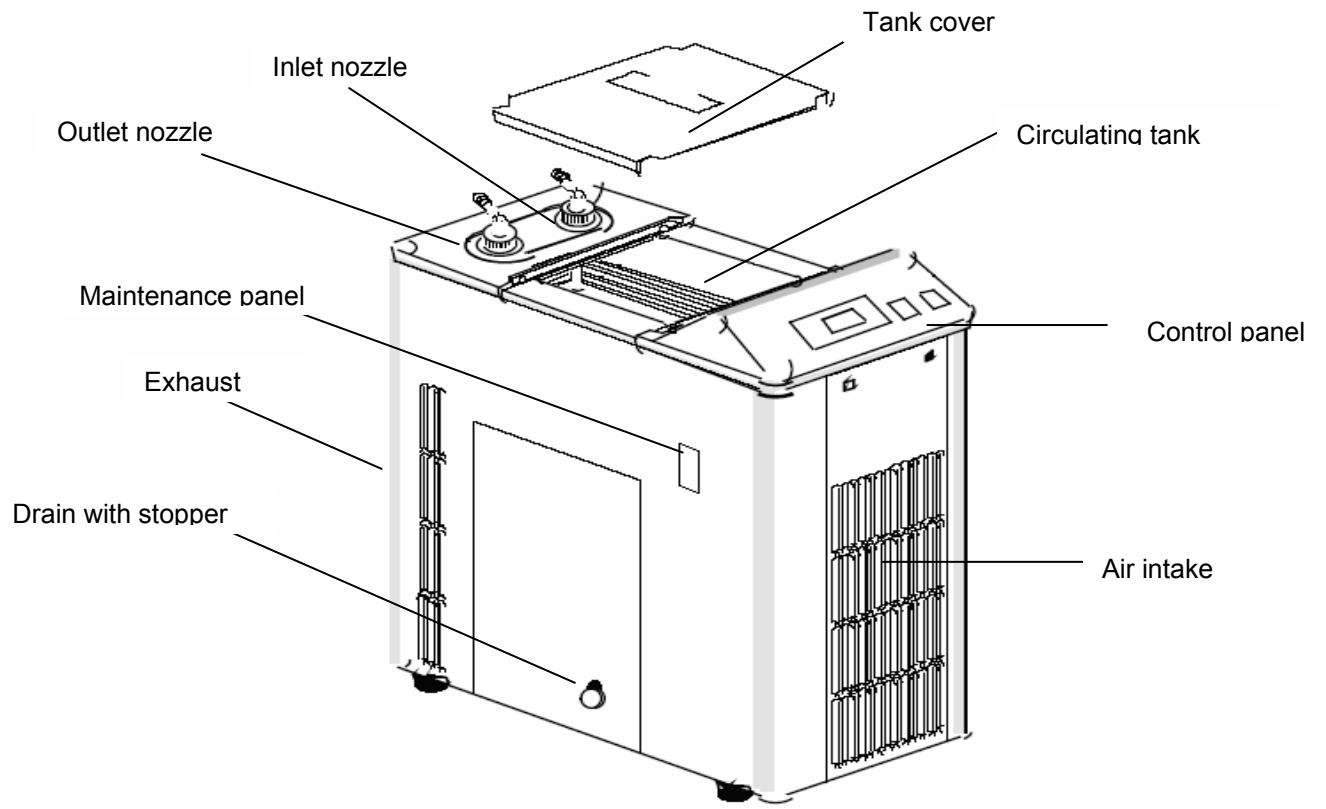

Thank you for purchasing this piece of Barloworld Scientific equipment. To get the best performance from the equipment, and for your own safety, please read these instructions carefully before use.

This equipment is designed to operate under the following conditions:-

- ❖ For indoor use only
- ❖ Use in a well ventilated area
- ❖ Ambient temperature range +5°C to +35°C
- ❖ Altitude to 2000m
- ❖ Relative humidity not exceeding 80%
- ❖ Mains supply fluctuation not exceeding 10%
- ❖ Overvoltage category II IEC60364-4-443
- ❖ Pollution degree 2 IEC664

If the equipment is not used in the manner described in this manual the protection provided by the equipment may be impaired.

Electrical Installation

THIS EQUIPMENT MUST BE EARTHED

Before connection please ensure that the line supply corresponds to that shown on the rating plate. This model requires a supply rated at 220 - 240V, 50 Hz, ~, single phase.

Power requirements

Model Wattage
SRC3 - 800W
SRC14 - 1.1kW

There is an IEC socket at the rear of the instrument for connection to the mains supply. The unit is supplied with two mains leads fitted with IEC plugs for connection to the instrument. One has a UK 3 pin plug and the other has a 2 pin "Shuko" plug for connection to the mains. Choose the lead appropriate for your electrical installation and discard the other. Should neither lead be suitable, take the lead with the UK plug and replace the plug with a suitable alternative.

See the enclosed instruction sheet for advice on how to carry out this procedure. Should the mains lead require replacement a cable of 1mm² of harmonised code H05W-F connected to an IEC 320 plug should be used.

IF IN DOUBT CONSULT A QUALIFIED ELECTRICIAN

The mains lead should be connected to the instrument BEFORE connection to the mains supply.

General Description

The Stuart Recirculating coolers accurately control the temperature of a cooling liquid between -20 to +20°C on the SRC3 and -20 to +30°C on the SRC14. The cooled liquid is then circulated to an external device via the inlet and outlet nozzle. The SRC3 has a capacity of 3 litres, the SRC14 has a capacity of 14 litres.

Safety Advice Before Use

- ❖ Beware some cooling mediums are ignitable above ambient temperatures, do not use with hazardous materials or liquids.
- ❖ Never move or carry the unit when in use or connected to the mains electricity supply.
- ❖ Please take care not to touch the cooling elements under the air filter, as these can be sharp.
- ❖ Do not place anything on top of the unit during operation

Installation

Position your recirculating cooler on a firm level surface. A byproduct of the air cooled refrigeration unit is heat, unnecessary heat build up can lower the cooling performance of the unit. To avoid this please ensure the unit is located in a well ventilated area. The unit should not be exposed to direct sunlight, humidity, dust or vibration. For optimum performance the following clearance should be allowed: SRC3: 3cm from both sides, 30cm above and behind the unit. SRC14: 20cm from both sides, 60cm above the unit and 40cm behind. Do not obstruct the front ventilation on either unit.

Care should be taken not to tilt the SRC3 by more than 15 degrees and the SRC14 by no more than 45 degrees for moving. Ensure that the castors on the SRC14 are locked prior to use (only the front 2 castors have stoppers).

Operation SRC3

Connection of hoses:

SRC3, Loosen the fixing nut (Fig. 1) and check that the o-ring is present and in good condition, turn the nozzle to point in the desired direction and tighten the fixing nut.

SRC14 connect the 90° elbows to the nozzles then connect the elbow adapters including flow control valve (Fig. 2) Connect hoses (ID 9mm) to each nozzle (inlet and outlet)

NOTE: Take care not to use excessive force connecting the hoses, use universal clips or similar to secure the tubing if necessary. Always consider the temperature and pressure requirements before selecting your tubing material. Use tubing of the minimum length required, excessively long tubing will reduce the efficiency of the unit.

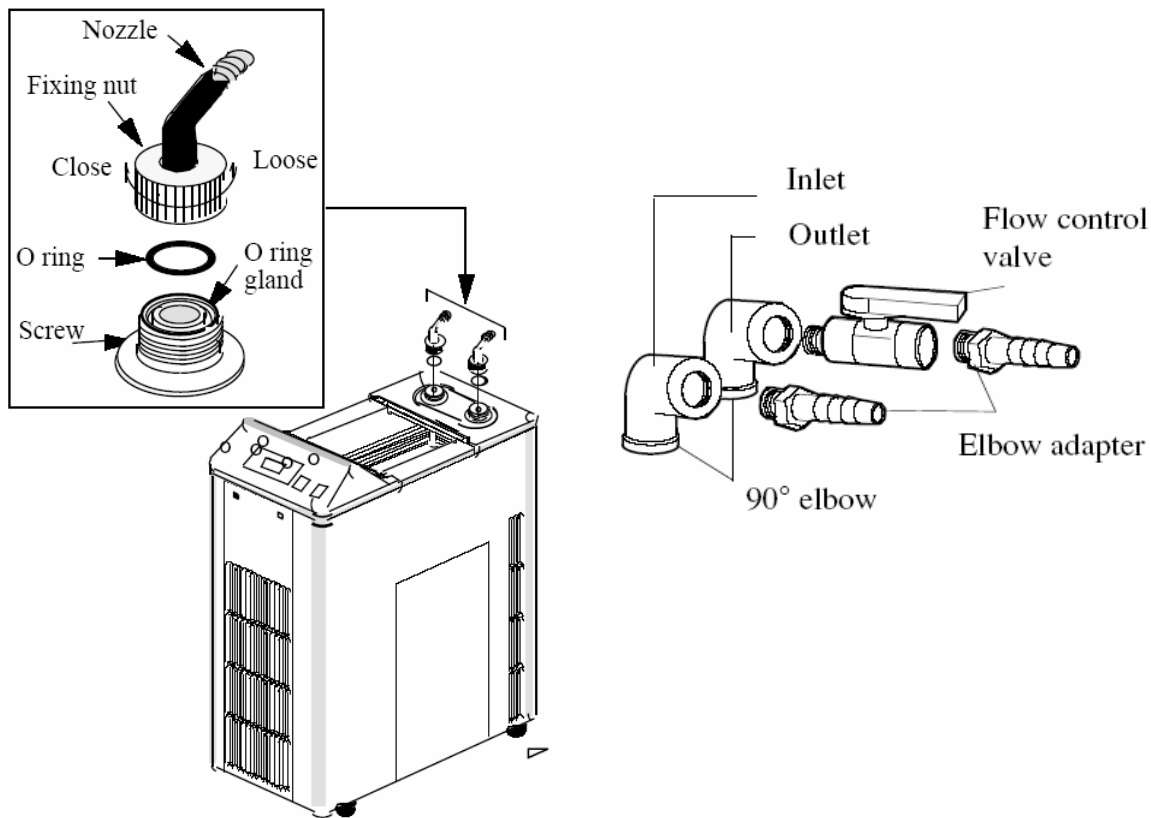

Fig. 1 Inlet/outlet nozzle assembly SRC3

Filling procedure:

When choosing your cooling medium you should take care that there is no risk of corrosion of internal parts, these include the following materials; copper, stainless steel, brass, PTFE, polyacetal resin, silicone rubber, polypropylene oxide and ethylene propylene rubber. Distilled water should also be avoided as it could dissolve metal substances in the circulation line. For operation below +7°C it is recommended that ethylene glycol is used as your cooling medium.

Prior to filling the unit make sure that the drain stopper is in place. Pour 3 litres (SRC3) or 14 litres (SRC14) of your cooling medium into the circulation tank, or until the liquid level is approximately 2 cm from the top of the tank, take care not to overfill. Replace the circulation tank cover.

Operation:

Connect the power lead to the IEC connector at the back of the unit. Make sure that the power switch and pump switch are in the off position on the control panel (Fig. 3+4) then connect the power cable to the mains supply. Turn the power switch on the main control panel to the on position. The display will show the current temperature of the cooling medium. The refrigeration unit will automatically start if the current temperature is 0.5°C higher than the set temperature (the temperature is set to 20°C before shipment) On the SRC14 the refrigerator must be switched on manually using the switch on the control panel, once on it will automatically cut in and out to control, the temperature of the cooling medium.

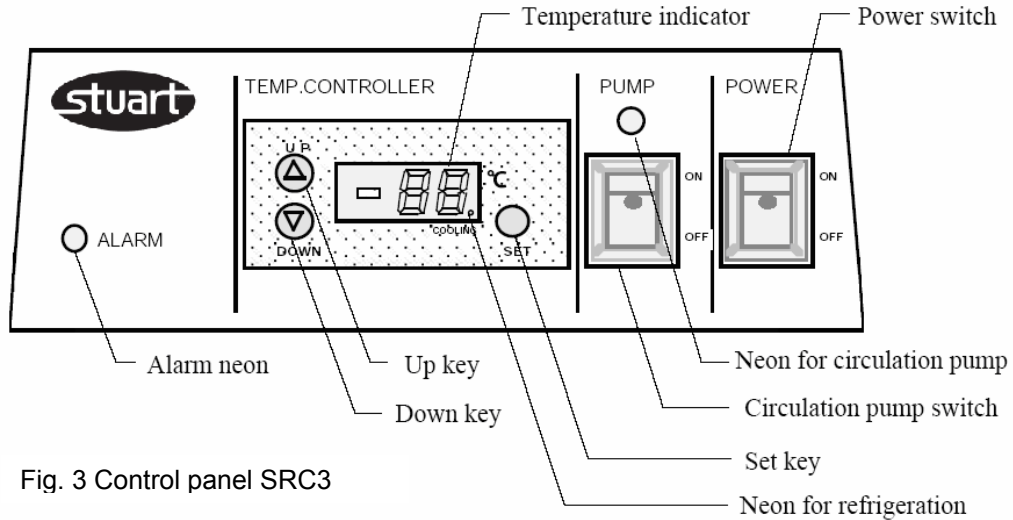

Fig. 3 Control panel SRC3

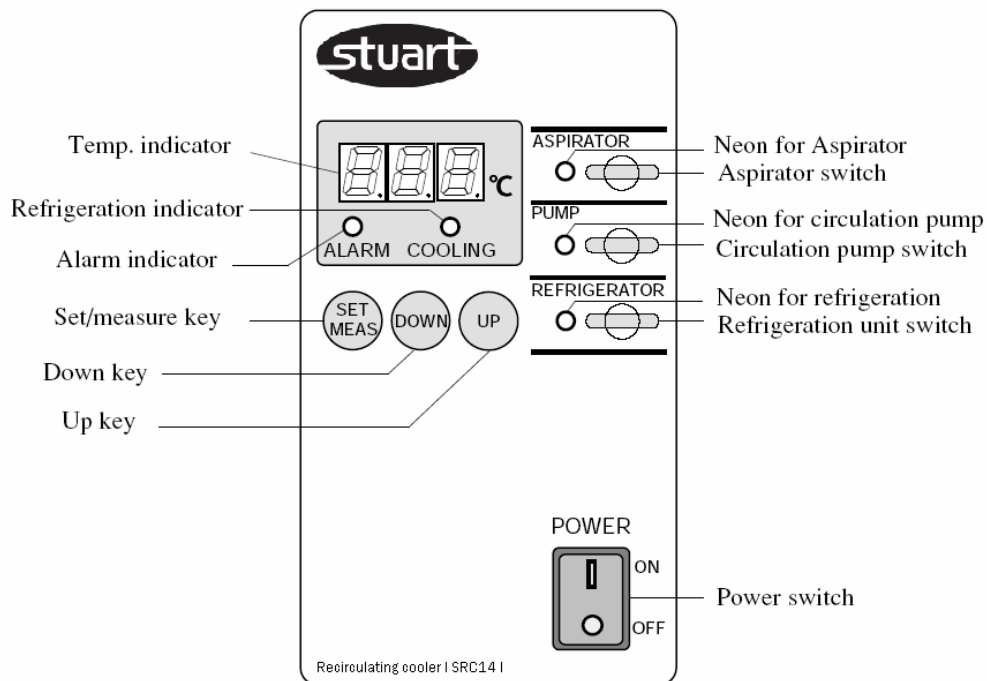

Fig. 4 Control panel SRC14

Setting the temperature:

To set the temperature of the cooling medium press the SET key once, the display will change from the current temperature to the set temperature (blinking) use the up and down keys to reach your desired value, hold down either key to scroll the temperature. After reaching the desired value press the set key again, the display will revert

to the current temperature. If the SET key is pressed once and no other key is pressed for five seconds the display will automatically revert to the current temperature. The set temperature is retained in the memory when mains power is switched off. The refrigeration unit will automatically start on the SRC3 when the current temperature exceeds the set temperature by $\geq 0.5^{\circ}\text{C}$, the refrigeration led will light during refrigeration. On the SRC14 the refrigerator must be switched on manually using the switch on the control panel, once on it will automatically cut in and out to control, the temperature of the cooling medium.

Connect the hoses to the appropriate device to be cooled. Turn the circulation pump on using the switch on the control panel, the circulation pump led will illuminate. Check for leaks on the hose connections. The level of the cooling medium will drop, top up the cooling medium if the cooling coil is exposed.

Adjustment of flow rate SRC14:

Use the flow rate valve on the outlet nozzle to adjust the flow rate, operation of the pump with this valve close could damage the pump. Take care when opening this valve, opening the valve too quickly could cause damage to the tubing or glassware in the circulation line.

Calibration of display temperature SRC14:

For normal operation it is not usually necessary to calibrate the temperature. Measure the temperature of the cooling liquid using a thermometer. Press the set key for more than 5 seconds. "Pb" will be displayed. Using the up and down key to select the correct value as measured on the thermometer. (calibration can only be performed between $+9.9^{\circ}\text{C}$ and -9.9°C) After setting the correct value press the set key for more than 5 seconds, the display will return to the current measured temperature.

After operation:

Switch the circulation pump off, then switch off the power switch and the mains power. Place an appropriate collection vessel for the cooling medium underneath the drain hose and remove the drain stopper. Once all fluid has been drained replace the drain stopper.

Maintenance & Servicing

WARNING: Ensure the unit is disconnected from the mains electricity supply before attempting maintenance or servicing.

Cleaning refrigeration air filter:

If the refrigeration air filter blocks it can affect the efficiency of the unit, periodically this filter should be checked and cleaned. Disconnect the unit from the mains power supply. The front panel is removable, press on the two black squares in the top corners of the front panel and the panel will open. Remove the filter, be careful not to touch the cooling elements as these can be sharp. Shake the dust out of the filter and wash with mild detergent if necessary. Allow the filter to air dry before replacement.

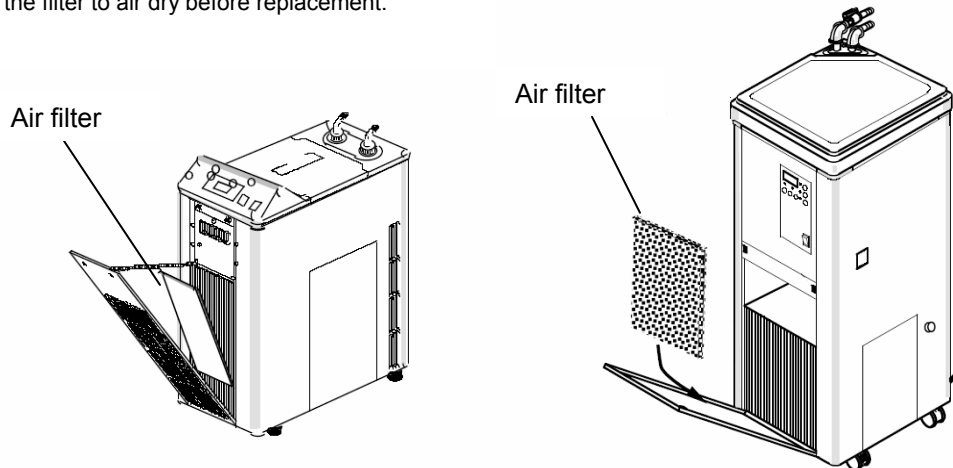

Cleaning of cooling liquid filter:

The cooling liquid filter is located at the bottom of the circulation tank. Drain the tank then remove the filter, it should easily pull free, clean and replace.

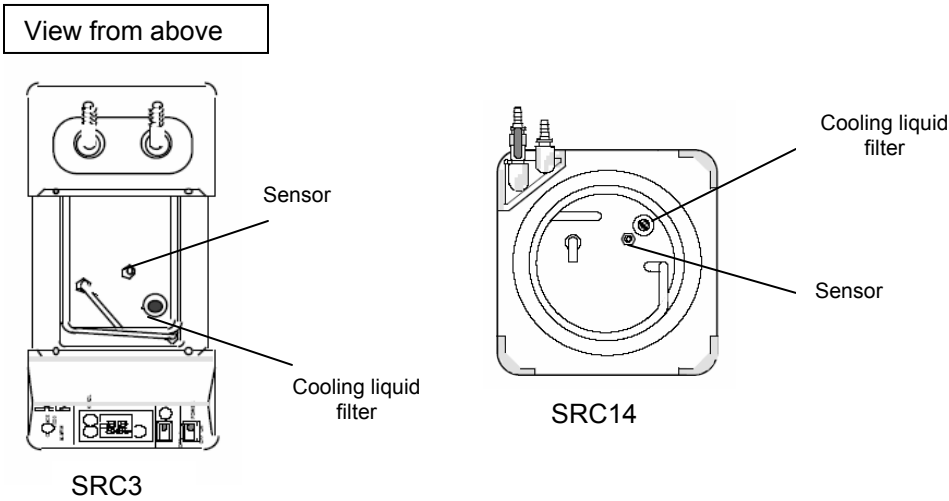

Periodically the inside of the circulation tank should be wiped clean, when empty. Use mild detergent if necessary. Regularly check connections for leakage. The condition of the o-ring in the inlet and outlet nozzle should be checked periodically and replaced if necessary.

At high temperatures or high humidity water can collect in the cooling system of the SRC14, this should be drained periodically via the hose located at the back of the unit. To change the fuse on the SRC14 switch off the mains power, insert a small screwdriver into the slot and push downwards, as shown in Fig. 5.

Fig. 5

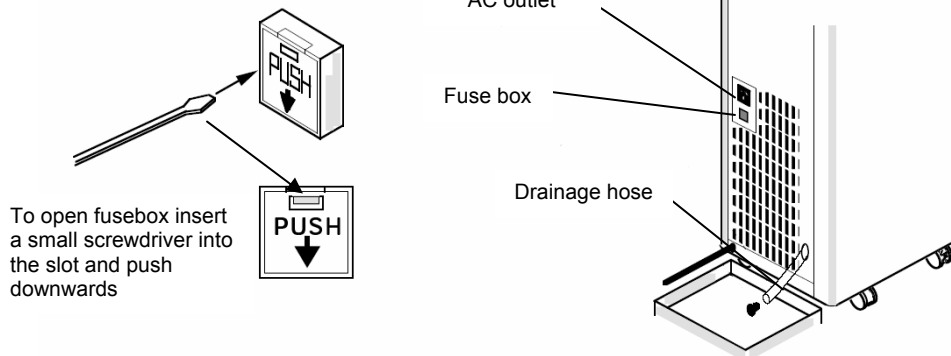

Any repairs or replacement of parts MUST be undertaken by suitably qualified personnel.

For a comprehensive list of parts required by service engineers conducting internal repairs and a service manual, please contact the Technical Service Department of Barloworld Scientific Ltd. quoting both the model and serial number. Only spare parts supplied or specified by Barloworld Scientific Ltd. or its agents should be used. Fitting of non-approved parts may affect the performance and safety features designed into the instrument. If in any doubt, please contact the Technical Service Department of Barloworld Scientific Ltd. or the point of sale.

Barloworld Scientific Ltd.

Stone, Staffordshire ST15 0SA

United Kingdom

Tel: +44 (0) 1785 812121





Fax: +44 (0) 1785 813748

e-mail equipment@barloworld-scientific.com

www.barloworld-scientific.com

Troubleshooting

Note: Alarm is cleared by turning off the power switch

Problem	Cause	Solution
Cooling liquid is not circulated	Cooling liquid filter is blocked	Clean the filter – See the maintenance and Service section for details. Briefly remove the drain stopper until all trapped air has been removed.
	Air is trapped in the pump	
Flow pressure is reduced	Tubing is trapped	Check the tubing isn't pinched, twisted or trapped
	Pressure loss due to excessive tubing length	Try to reduce the overall length of the tubing
	The circulator is too low compared to the device it is cooling	Adjust the position of the recirculating cooler
No refrigeration of cooling medium	Refrigeration unit is broken	Contact your local service representative
	The cooling medium isn't sufficiently covering the cooling coil	Top up the cooling medium
	Overload of refrigeration unit (alarm led illuminates)	Lower ambient temperature below 35°C, or raise set temperature
Display does not illuminate when power is on	No mains power Circuit breaker has tripped	Check mains power supply Unscrew maintenance panel and check switchable circuit breaker is in the on position. If problem persists there could be an electrical leakage and you should contact your local service representative. Follow procedure to change fuse in maintenance and service Contact local service representative
	SRC14: fuse has blown	
	Temperature controller is broken	
Cooling power is poor	Refrigeration unit does not work	Contact local service representative
	The ambient temperature exceeds 35°C	Try to lower the ambient temperature
	Exhaust is blocked	Check necessary clearance around the unit has been allowed
	Refrigeration air filter is blocked	Follow the procedure detailed in the Maintenance and Service section to clean the filter
Water freezes in the circulation tank at +7°C	Loss of flow pressure	<ul style="list-style-type: none"> Check flow pressure, see above Use anti freeze for cooling medium.
 Blinks on the display	<ul style="list-style-type: none"> Temperature sensor malfunction Measured temperature is lower than units lower limit (-50°C) 	Contact local service representative
 Blinks on the display, refrigeration stops	Temperature sensor short circuit	Contact local service representative
	Measured temperature exceeds the upper limit of the unit (more than +40°C)	The heating load exceeds capacity, reduce load
Display is abnormal or unstable:  	Electrical noise causes abnormal display on temperature controller	Turn off mains power, wait 5 seconds then switch back on
	Temperature controller is reset by electrical noise	Move unit to a new location
	Ambient temperature exceeds 35°C	Lower ambient temperature below 35°C

Warranty

Barloworld Scientific Ltd warrants this instrument to be free from defects in material and workmanship, when used under normal laboratory conditions, for a period of three (3) years. In the event of a justified claim Barloworld Scientific will replace any defective component or replace the unit free of charge. This warranty does NOT apply if damage is caused by fire, accident, misuse, neglect, incorrect adjustment or repair, damage caused by incorrect installation, adaptation, modification, fitting of non approved parts or repair by unauthorised personnel.

Technical Specification

	SRC3	SRC14
Cooling capacity	450W at 10°C	1200W at 10 °C
Temperature range	-20 to +20°C	-20 to +30 °C
Control accuracy	±2°C	±2°C
Bath capacity	3 litres	14 litres
Pump rate	10 litres / minute	18 litres / minute
Dimensions (w x d x h)	206 x 401 x 540mm	354 x 384 x 851mm
Net weight	25kg	41kg
Electrical supply	230V, 50Hz	230V,50Hz